

LoadMaxx Installation Guide



Tractors with a Hydraulic Lift

MODEL 5809

Air-Weigh Customer Support: 888-459-3247

Table of Contents

Scale Overview.....	1
Tools Required.....	1
LoadMaxx Tractor Scale Overview.....	2
Installing Hydraulic Sensor.....	3
Installing the LoadMaxx Display.....	4
Preparing the Cab Display for Installation.....	4
Installing the Cab Display.....	4
Mounting the ComLink Behind Dash.....	5
Installing the ComLink.....	5
Connecting the ComLink Wiring Harness.....	6
Connecting the ComLink to Power.....	6
Secure Cables and Reassemble the Dash.....	7
Changing the scale model number.....	7
LimitedWarranty.....	8
Procedure for Warranty Claims.....	9

Scale Overview

The Air-Weigh Scale for vehicles such as yard tractors with a hydraulic lift includes a dashboard-mounted display, a LoadMaxx ComLink, mounting cables, hydraulic sensor cable, and hydraulic pressure sensor.

Follow the installation procedures in this guide exactly for the most accurate weighing.

Tools Required

The list below contains the tools and other materials (customer supplied) to properly install.

- Screwdrivers – flathead and/or Philips
- Assorted wrenches
- Drill
- 2 1/8" hole saw
- Optional 3/4" hole saw for running air line to dash
- Safety glasses
- Wire cutter
- Crimper
- Hydraulic thread sealant/tape

LoadMaxx Tractor Scale Overview

LoadMaxx is a weighing system for vehicles that works by using a hydraulic lift sensor. The sensor measures hydraulic lift pressure changes and converts that number into weight which is displayed in the truck cab. The scale will display the actual on-ground weight for the hydraulic lift axle group.

Any tractor equipped with a LoadMaxx Tractor Scale will automatically display trailer weight data from Air-Weigh equipped trailers. No re-calibration or trailer ID entry is required. No special tractor/trailer connection is necessary because trailer weight data is transmitted over the vehicle's existing 7-wire cable (J-560) without any interference. This is a true drop and hook application.

Note: Following installation, you must calibrate the scale before you can use it to determine axle group and vehicle weight.

Checking Your Model Number

After installation, it is important to check that your LoadMaxx scale is programmed with the correct model number before you begin calibration. Although scales come pre-programmed with the model number requested during purchasing, we recommend that you check the model number again prior to calibration. The LoadMaxx scale for Hydraulic sensors should read 5809. If your scale is programmed to the wrong model number see pg. 7 to change the model number.

Installing Hydraulic Sensor

The hydraulic sensor measures hydraulic pressure. The sensors are equipped with 7/16-20 UNF SAE J1926/2 male port threads. A nitrile o-ring is included with the sensor and required for installation.

Depending on the yard tractor and its hydraulic system, you may need to use additional fittings that are not provided with the Air-Weigh kit.

It's recommended you obtain a Tee Test Point Fitting - # 6564-FG (6564-08-08-04) 3/4"-16 Male JIC x 3/4"-16 Female JIC Swivel x 7/16"-20 Female O-Ring Boss.



**Tee Test Point Fitting
6564-08-08-04**

1. Find a suitable location to tee into the hydraulic line between the lift cylinder and the spool valve. Ensure that the selected location is on the high pressure side of the cylinder and will not be impacted by moving parts.
2. Disconnect the hydraulic line from the high pressure side.
3. If using the Tee Test Point Fitting (user supplied) install the female end of the Tee Test Point Fitting.
4. Connect the hydraulic line to the male side of the Tee Test Point Fitting and tighten securely.
5. Install the hydraulic sensor to the Tee Test Point Fitting and tighten securely.
6. Connect the sensor cable to the sensor.
7. Pressurize the hydraulic lift cylinder and check for leaks.
8. Route the supplied 30' sensor cable from the sensor to the dash, this will be plugged into the **ComLink Port A**.

Installing the ComLink and Display

The Optional Universal Mounting Pod can be used for installations where there is no space in the dash to mount the scale display.

Preparing the Cab Display for Installation

1. Select a location for the display (1) on the dash panel (5) with at least 3" of clearance behind the dash panel (5) for the unit and its connections. A higher dash position provides better visibility.
2. Using a hole saw, cut a 2-1/8" hole (2) in the dash where you will mount the display.
3. Remove the hex nuts (4) from the studs (6) on the back of the display (1) to release the mounting bracket (3).

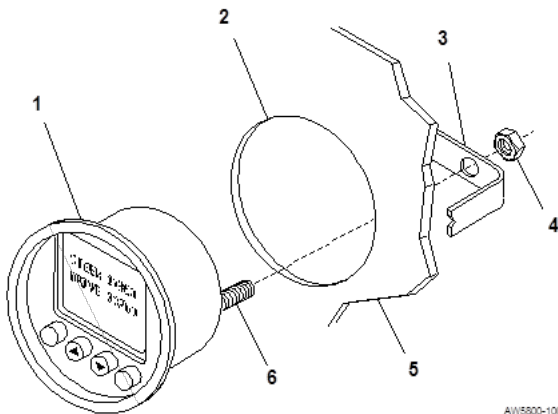

AW/5800-1001

Display Preparation and Installation

Installing the Cab Display

1. Position the display (1) in the hole so it is level on the dash.
2. Reinstall the mounting bracket (3) on the back of the display (1) and secure with two nuts (4) on the display studs (6). Tighten the nuts (4) and secure the display (1) to the dash using 6 in-lbs. of torque. **Do not over-tighten the mounting bracket nuts (4).**

Installing the ComLink

Select a location behind the dash for the LoadMaxx ComLink, ensure there is adequate access to the scale and the electrical connections.

The LoadMaxx ComLink should be oriented with the connectors facing downward and installed by any of the following three methods, using the hardware provided.

1. Use wire ties through the holes in the ComLink mounting ears to secure it to any appropriate wire harness behind the dash.

- OR -

2. Find a flat location where the ComLink can be attached using the 2-sided adhesive tape on the back of the ComLink. Remove all dust, grease or debris from the flat location, using the supplied alcohol pad. Remove one or both of the red strips from the back of the ComLink, exposing the adhesive tape. Place the ComLink against the cleaned flat area and apply 15lbs of steady pressure for 60 seconds to ensure adhesion. For best results, push the ComLink into place using steady force, being careful not to crack the case. Using this method will make the ComLink more difficult to remove.

- OR -

3. Use self-tapping screws to secure the ComLink to its location.

NOTE: If you are using the optional printer, please see the document Printer Installation Instructions for information on connecting the printer to the ComLink.

Connecting Cables

The provided cables are used to connect the ComLink to the vehicle's electrical system, to the dash display unit, and, if desired, to an alarm output.

Power and Ground Table	
White Wire	Vehicle Chassis Ground
Pink/Black Wire with In-Line Fuse	12VDC or 24VDC Key Hot Power
Gray Wire/Brown Wire	Alarm output 1 and 2 (same voltage as vehicle power)
Black Wires	Alarm ground Return 1 and 2

1. Connect the white wire to chassis ground.
2. Connect pink/black wire with inline fuse to the positive (+) or "hot" side of the 12 VDC or 24 VDC key hot power source. DO NOT connect directly to battery.
3. Connect the 10-pin plug of the power interface cable to the ComLink module.
4. Connect both the 2-pin and the 4-pin plugs of the power interface cable to the display.
5. When using an alarm, connect the alarm output wire and the ground return wire to the desired device.

Securing Cables and Reassembling the Dash

1. Connect the extension cable to the ComLink module in the dash. Drive cable should be connected to Port A and B, steer cable should connect to Port C.
2. Coil and secure any excess wire using zip ties.
3. Tighten all zip ties and trim.
4. Reassemble the dash assembly after all sensors have been installed (next section) and sensor cables are connected. Ensure all connections are tight.

Secure Cables and Reassemble the Dash

1. Coil excess wires and harnesses and secure using zip ties.
2. Tie wires and sensor assemblies to other secured harnesses, to prevent damage due to vibration.
3. Reassemble the dash assembly. Ensure all connections are tight.

Note: Cable to the sensor, and any other Air-Weigh wiring, must be separated by a minimum of 12 inches, or properly shielded, from exhaust piping.

Checking Your Model Number

It is important that your LoadMaxx scale is programmed with the correct model number before you begin calibration. The LoadMaxx for Hydraulic sensors should read 5809.

Turn on your vehicle's ignition. The scale display should light up and read AIR-WEIGH with the 4 digit model number below

To change your model number:

1. From the weight display, press **ESC** to reach the main menu
2. Press **▼** until **PRINT, SETUP** is flashing. Press **ENTER**
3. Press **▼** until **SYSTEM SETUP** is flashing. Press **ENTER**
4. Press **▼** until **SYS CONFIG** is flashing. Press **ENTER**
5. Press **▼** until **SCALE TYPE** is flashing. Press **ENTER**
6. The screen will read **USE CAUTION! PUSH ENTER TO CONTINUE**. Press **ENTER**
7. **MODEL NUMBER** will flash. Press **ENTER**
8. Use **▲** or **▼** to select the correct model number. Press **ENTER**
9. The screen will read **ACCEPTED**

Limited Warranty

Air-Weigh warrants (the "Limited Warranty") that the Products will be free from defects in material and workmanship under normal use and service with proper maintenance for the following time periods:

- (a) for new Scale kits, the Limited Warranty period will be 3 years;
- (b) for new parts and accessories sold separately, the Limited Warranty period will be 1 year; and
- (c) for repaired or refurbished items, including repaired or refurbished Scale kits and repaired or refurbished parts and accessories sold separately, the Limited Warranty period will be 90 days.

If any Product is determined to not conform to this Limited Warranty during its applicable Limited Warranty period, Air-Weigh will, at its exclusive option, either repair or replace the Product.

Limitations of Limited Warranty. Air-Weigh will have no obligation under the Limited Warranty with respect to any product if (a) Buyer fails to notify Air-Weigh in writing during the warranty period of a non-conformity, or (b) Buyer or any other person, entity, or governmental authority uses, misuses, or neglects the product in a manner inconsistent with the product's specifications or directions for use or maintenance, modifies the product or improperly installs, handles, or maintains the product.

No Repair or Modification of the products. Except as explicitly authorized or in a separate written agreement with Air-Weigh, Buyer will not service, repair, modify, alter, replace, reverse engineer, or otherwise change any of the products.

Disclaimer of All Other Warranties. EXCEPT FOR THE LIMITED WARRANTIES SET OUT ABOVE, NEITHER AIR-WEIGH NOR ANY PERSON OR ENTITY ON AIR-WEIGH'S BEHALF HAS MADE OR MAKES FOR BUYER'S BENEFIT ANY EXPRESS OR IMPLIED REPRESENTATION OR WARRANTY WHATSOEVER, INCLUDING ANY WARRANTIES OF: (i) MERCHANTABILITY; (ii) FITNESS FOR A PARTICULAR PURPOSE; (iii) TITLE; OR (iv) NON-INFRINGEMENT; WHETHER ARISING BY LAW, COURSE OF DEALING, COURSE OF PERFORMANCE, USAGE OF TRADE OR OTHERWISE, ALL OF WHICH ARE EXPRESSLY DISCLAIMED. BUYER ACKNOWLEDGES THAT IT HAS NOT RELIED ON ANY OTHER REPRESENTATION OR WARRANTY MADE BY AIR-WEIGH, OR ANY OTHER PERSON OR ENTITY ON AIR-WEIGH'S BEHALF.

Limitation of Liability.

IN NO EVENT WILL AIR-WEIGH BE LIABLE FOR CONSEQUENTIAL, INDIRECT, INCIDENTAL, SPECIAL, EXEMPLARY, PUNITIVE, OR ENHANCED DAMAGES, LOST PROFITS OR REVENUES, OR DIMINUTION IN VALUE, ARISING OUT OF OR RELATING TO ANY BREACH OF THESE TERMS, REGARDLESS OF WHETHER OR NOT THE DAMAGES WERE FORESEEABLE, WHETHER OR NOT AIR-WEIGH WAS ADVISED OF THE POSSIBILITY OF THE DAMAGES, OR THE LEGAL OR EQUITABLE THEORY (CONTRACT, TORT, OR OTHERWISE) ON WHICH THE CLAIM IS BASED.

IN NO CASE WILL AIR-WEIGH'S AGGREGATE LIABILITY ARISING OUT OF OR RELATED TO THESE TERMS, WHETHER ARISING OUT OF OR RELATED TO BREACH OF CONTRACT, TORT (INCLUDING NEGLIGENCE), OR OTHERWISE, EXCEED THE TOTAL OF THE AMOUNTS PAID TO AIR-WEIGH FOR THE PRODUCTS.

THE FOREGOING LIMITATIONS APPLY EVEN IF BUYER'S REMEDIES UNDER THESE TERMS FAIL OF THEIR ESSENTIAL PURPOSE.

Procedure For Warranty Claims

ALL customers should first contact Air-Weigh Customer Support Department at (888) 459-3247 for questions regarding the use, operation, repair or return of any Air-Weigh product.

In the event Air-Weigh requests to examine the product prior to disposition OR for repair or replacement, Air-Weigh requires a Return Material Authorization (RMA) number be issued before the item is returned. Customer Support will issue the RMA number. Please reference this RMA number in all correspondence.

Claimed items shall be shipped freight pre-paid to:

Air-Weigh
Customer Support Department
1720 Willow Creek Circle, Suite 510
Eugene, Oregon 97402, USA

The Air-Weigh RMA number **must** appear on the outside of the return packaging. Air-Weigh shall examine returned material within 30 days after receipt, or sooner if mutually agreed upon. If Air-Weigh determines that the part or assembly was defective in material or workmanship and within the warranty period, Air-Weigh will repair or replace the part or assembly and return freight pre-paid. In the event Air-Weigh determines that the part or assembly cannot be repaired or replaced and is within the warranty period, a credit not to exceed the purchase price will be issued to the Air-Weigh customer.

For our customers using purchase orders Air-Weigh will process a credit memo and notify the customer by email or fax. The customer will process a corresponding debit memo and notify Air-Weigh accordingly.

If the part or assembly received by Air-Weigh does not meet the requirements of the warranty program set forth above, at the Air-Weigh customer's request the part or assembly will either be discarded, returned freight collect, or repaired or replaced at the Air-Weigh customer's expense and returned freight collect.

Air Weigh

1730 Willow Creek Circle • Eugene, OR 97402-9152 USA
P.O. Box 24308 • Eugene, OR 97402-0437 USA

Telephone (541) 343-7884 • Order Desk (888) 459-3444
Customer Support (888) 459-3247 • Fax (541) 431-3121

www.Air-Weigh.com