

LoadMaxx Installation Guide



**for Trucks and Tractors with
Single, Dual, 6x2 and Dedicated
Air Pressure Drive**

Air-Weigh Customer Support: 888-459-3247

Table of Contents

Scale Overview	2
Tools Required	3
Installing Air Pressure Sensor(s)	4
Air Line Installation for Each Leveling Valve.....	4
Route Air Line from Air Suspension.....	5
Route Air Line for Dedicated Trailers	6
Installing Air Pressure Sensor(s).....	7
Installing the LoadMaxx Interior Hardware	9
Installing the Tractor Cab Display.....	9
Preparing the Cab Display for Installation.....	9
Installing the ComLink.....	10
Connecting the ComLink Wiring Harness.....	11
Connecting the ComLink to Power.....	11
Secure Cables and Reassemble the Dash.....	12
Sensor Configuration Chart	13
Overview for other AP Sensor(s) Installation.....	18
Limited Warranty	17
Procedure for Warranty Claims	18

Scale Overview

The Air-Weigh Scale for trucks and tractors with AP (Air Pressure) drive suspension includes a dashboard-mounted display, a LoadMaxx ComLink, mounting cables, air sensor cable(s), and air pressure sensor(s) with a street-T.

The scale displays the actual on-ground weight of each axle group to within 300 pounds (140 kilograms). An axle group is defined by the Height Control Valve(s) (HCV), or leveling valve(s), on the air suspension. For instance, a tandem drive axle suspension typically has only one HCV. Two drive axles make up a single group and the displayed weight will be for the total tandem weight.

The LoadMaxx on-board scale can display up to nine axle groups on one tractor/trailer combination. Once the LoadMaxx scale is calibrated, it is not necessary to recalibrate unless the suspension characteristics change. Air-Weigh recommends verifying accuracy by checking weight at least once per year.

Tractors equipped with a LoadMaxx tractor scale will automatically display a LoadMaxx equipped trailer's weight data that includes a communication cable. No re-calibration or trailer ID entry is required. No special tractor/trailer connection is necessary because trailer weight data is transmitted over the vehicle's existing 7-wire cable (J-560). This is a true drop and hook application.

Note: Following installation, you must calibrate the scale before you can use it to determine axle group and vehicle weight. For instructions on calibration, please consult the: LoadMaxx User Manual, found within your kit or at www.air-weigh.com

Tools Required

The list below contains the tools and other materials (customer supplied) to properly install the AP Drive Sensor(s) on the tractor.

- Screwdrivers – flathead and/or Phillips
- Assorted wrenches
- Drill
- 2 1/8" hole saw
- Optional 3/4" hole saw for running air line to dash
- Safety glasses
- Wire cutter
- Crimper
- Teflon pipe thread tape

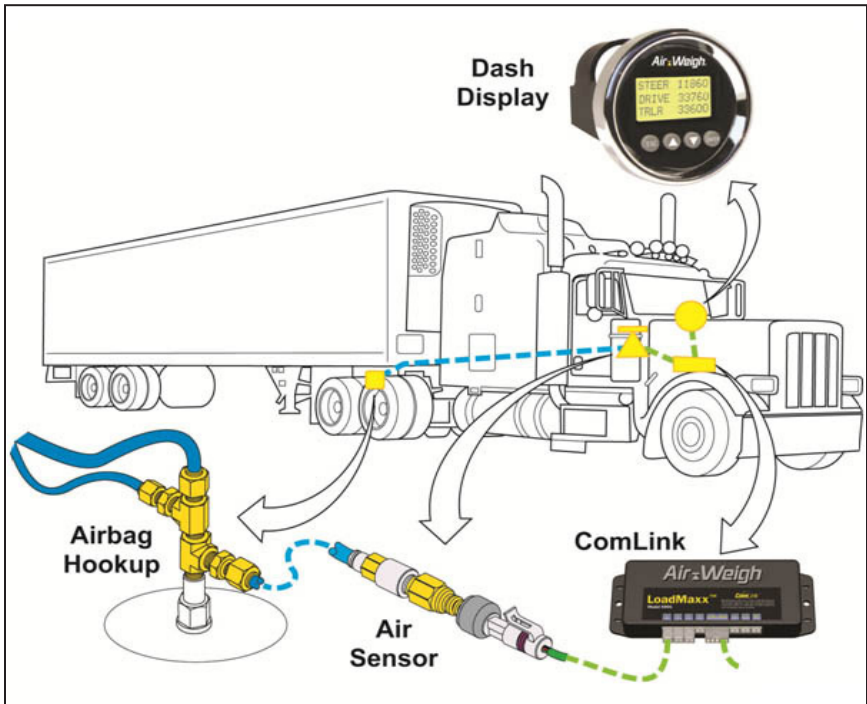

Installation Overview

Note: The following order of installation instructions is a guide. If you wish to install the dash components prior to the sensor(s) it will not effect the install process.

Installing Air Suspension Sensor(s)

Air Line Installation for each leveling valve

Route the air line from the air suspension to behind the dashboard.

You will install one sensor per leveling valve or per tandem axle, in the case of a 6x2 tractor/truck.

For dual hight control valve air suspensions, the leveling valves will be found on the left and right. For 6x2 tractors/trucks, they will be in the front and rear.

If a tractor air suspension gauge already exists in the dash, skip to the Installing Sensor(s) section. Otherwise, continue with this procedure.

Follow the same instructions for air line and sensor installation for both drive suspensions.

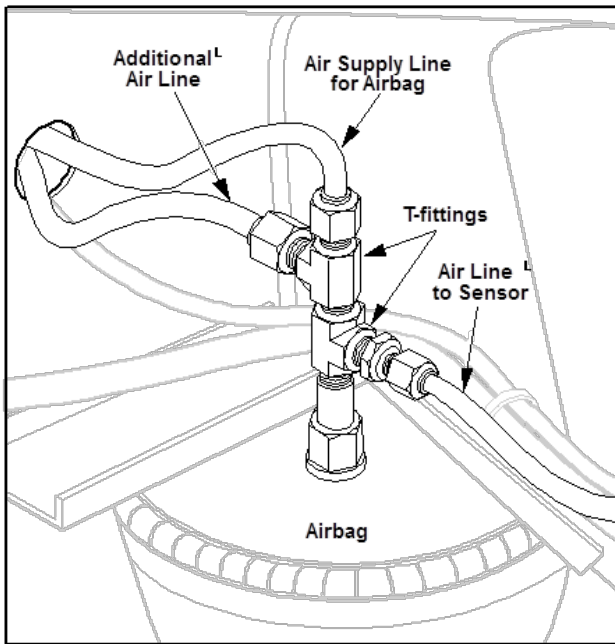

1. Route a ¼-inch air line from the airbag suspension to the dash. If part number 010-0023 was not ordered with your order, you will need to source an air-line and fitting.
2. Use a ¼-inch straight street-T at the top of a convenient drive axle suspension air bag to access air pressure. If you choose to connect in the middle of an existing air line between two air bags, thoroughly remove any paint on the air line and wipe clean before cutting the air line.
3. Route the air line along with other air lines and cables into the dash. Loosely connect the air line to the other air lines and cable with cable ties to prevent it from being damaged.

Note: Avoid connecting on the air bag's supply line or a lift/auxiliary axle.

Routing Air line for Dedicated Tractor / Trailer Scale

Requires additional part #010-0028-000

1. Remove existing air line connection from one trailer air bag.
2. Install street-T into air bag.
3. Install fitting into side of street-T and connect to air line.
4. Reinstall original air line and fitting connector to top of street-T.
5. Run air line to front of trailer. Secure with cable ties.
6. Drill hole for trailer bulkhead fitting at a point near where existing airlines attach to trailer.
7. Install bulkhead fitting.
8. Cut air line to length and connect to rear side of bulkhead fitting. Use remaining air line in step 13.
9. Attach female quick-disconnect coupling to face of bulkhead fitting.
10. Connect end of coiled air line with male quick disconnect coupling to female quick disconnect coupling.

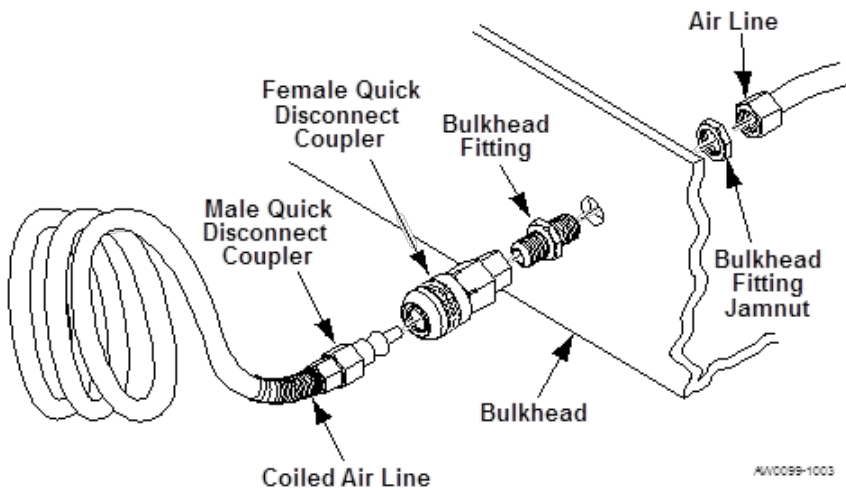

AIN0099-1003

11. Attach quick disconnect fitting to one end of coiled air hose and couple to quick disconnect fitting on front bulkhead of trailer.
12. Drill hole in tractor bulkhead near where existing air lines attach to the tractor and install bulkhead fitting.
13. Connect the other end of the coiled air line to the face of the bulkhead fitting.
14. Install brass fitting into rear of bulkhead fitting. Run air line from brass fitting to under dash, close to ComLink mounting location. Secure with cable ties.
15. Connect open end of air line, near ComLink, to push-on fitting on end of Air Pressure Sensor.
16. Connect electrical cable from opposite end of air pressure sensor to appropriate port on ComLink. See the Kit Configuration Sensor Assignment Table to determine the appropriate port for the sensor connector.

Installing Air Pressure Sensor(s)

Note: Avoid dropping the sensors. Dropping can cause the sensors to fail immediately or shorten their lifespan.

There are two options for installing the sensor connections:

1. Insert a T-fitting into an existing suspension air gauge to tap into the existing suspension pressure gauge.
2. Run a new air line from the air bag and terminate the air line into the nickel plated brass fitting supplied by Air-Weigh.

The Air-Weigh kit includes fittings for terminating an air line of ¼ inch. Air-Weigh only supplies the connectors needed for a terminated connection. Additional T-fittings may need to be purchased separately.

1. Connect sensor to fitting and tighten firmly.
2. Push end of air line into fitting and ensure connection is firmly secured.

Note: While the air line can be removed from the fitting by retracting the O-ring while gently pulling the air line out, repeated removal and replacement will weaken the seal.

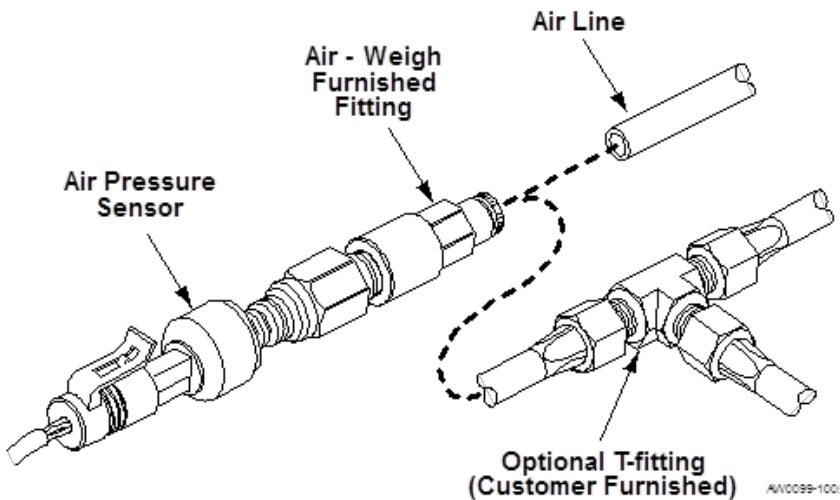

Connecting the Air Pressure Sensor

Installing Scales with a Steer Axle Deflection Sensor

Note: When installing kits with configurations 5807, 5808, 5843, 5846, 5853, 5857 or 5878, which include steer axle deflection sensors, refer to the Steer Axle Deflection Sensor Kit Installation Guide.

Installing the ComLink and Display

The Optional Universal Mounting Pod can be used for installations where there is no space in the dash to mount the scale display.

Preparing the Cab Display for Installation

1. Select a location for the display (1) on the dash panel (5) with at least 3" of clearance behind the dash panel (5) for the unit and its connections. A higher dash position provides better visibility.
2. Using a hole saw, cut a 2-1/8" hole (2) in the dash where you will mount the display.
3. Remove the hex nuts (4) from the studs (6) on the back of the display (1) to release the mounting bracket (3).

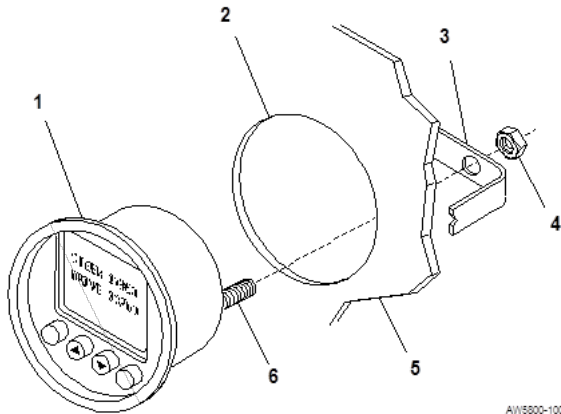

Display Preparation and Installation

Installing the Cab Display

1. Position the display (1) in the hole so it is level on the dash.
2. Reinstall the mounting bracket (3) on the back of the display (1) and secure with two nuts (4) on the display studs (6). Tighten the nuts (4) and secure the display (1) to the dash using 6 in-lbs. of torque. **Do not over-tighten the mounting bracket nuts (4).**

Installing the ComLink

Select a location behind the dash for the LoadMaxx ComLink, ensure there is adequate access to the scale and the electrical connections.

The LoadMaxx ComLink should be oriented with the connectors facing downward and installed by any of the following three methods, using the hardware provided.

1. Use wire ties through the holes in the ComLink mounting ears to secure it to any appropriate wire harness behind the dash.

- OR -

2. Find a flat location where the ComLink can be attached using the 2-sided adhesive tape on the back of the ComLink. Remove all dust, grease or debris from the flat location, using the supplied alcohol pad. Remove one or both of the red strips from the back of the ComLink, exposing the adhesive tape. Place the ComLink against the cleaned flat area and apply 15lbs of steady pressure for 60 seconds to ensure adhesion. For best results, push the ComLink into place using steady force, being careful not to crack the case. Using this method will make the ComLink more difficult to remove.

- OR -

3. Use self-tapping screws to secure the ComLink to its location.

NOTE: If you are using the optional printer, please see the document Printer Installation Instructions for information on connecting the printer to the ComLink.

Connecting the ComLink Wiring Harness

Connecting the ComLink to Power

The ComLink wiring harness connects the Air-Weigh scale system to the vehicle's power and ground circuits, and connects the ComLink to the scale display and to the alarm output of a customer-provided warning device.

The 2 pin and 4 pin connectors plug into the scale display. For wires without connectors, consult the Power and Ground Table.

Power and Ground Table

White Wire	Vehicle chassis ground
Blue/Black Wire with In-Line Fuse	12VDC or 24VDC ignition hot power
Gray Wire/Brown Wire	Alarm Output 1 and 2 (same voltage as vehicle power)
Black Wires	Alarm Ground Return 1 and 2

1. Connect the white wire to chassis **ground**.
2. Connect blue/black wire with **in-line fuse** to the positive (+) or "hot" side of the 12 VDC or 24 VDC ignition power source. **DO NOT connect directly to battery.**
3. Connect the **10-pin plug** of the wiring harness to the ComLink.
4. Connect both the **2-pin** and the **4-pin** plugs of the wiring harness to the display.

5. Connect electrical cable from opposite end of air pressure sensor to appropriate port on ComLink. See the **Kit Configuration Sensor Assignment Table on pg. 13** to determine the appropriate port for the sensor connector.
NOTE: One of the most common install errors is plugging the sensors into the incorrect ports.

6. When using an alarm, connect the **alarm output wire and the ground return wire** to the desired device (buzzer, horn, light, etc.). Ensure that any unused alarm wires are electrically insulated. Audible alarms require an additional relay. **NOTE:** Do not connect directly to the battery.

Note: Air lines and cables to the sensor, and any other Air-Weigh wiring, must be separated by a minimum of 12 inches, or properly shielded, from exhaust piping.

NOTE: 2012-2019 Freightliner Cascadia Tractors may require a different power location

2019	F-74, F-75 or F-76
2013-2018	F-7, F-8, F-9, F-10, F-11 or F-12
2012	F-25

**Full service bulletins can be referenced at:
www.air-weigh.com.**

For these specific tractors, route the power wire through the dash to the fuse panel and connect the power wire to the specific power source.

Secure Cables and Reassemble the Dash

1. Coil excess wires and secure using nylon cable ties.
2. Cable tie wires and sensor assemblies to other secured harnesses, to prevent damage due to vibration.
3. Reassemble the dash assembly. Ensure all connections are tight.
4. Turn the ignition key **ON** and perform a final system check.

Note: The scale will only display accurate weights after it has been completely calibrated to a certified in-ground scale, by entering empty and loaded axle weights into the Air-Weigh Scale. Enter empty weights only when the vehicle is empty! Enter loaded weights only when the vehicle is loaded!

See LoadMaxx Calibration and Operations Manual for Calibration and user instructions.

Overview for other AP Sensor(s) Installation

- For scales with a steer axle with air suspension (configurations 5805, 5806, 5815, 5821, 5826, 5827, 5838, 5842, 5852, 5856), route air line(s) from steer axle suspension to sensor(s) installed under dash.
- For scales with one or more lift axles (configurations 5835, 5836, 5838, 5864), route air line from lift axle suspension to sensor installed under dash.
- For Dedicated Tractor/Trailer Scales (configurations 5840 – 5860), route trailer suspension air line(s) to sensor(s) installed under dash.
- For scales which calculate the weight at the steer axle from the drive axle suspension (configurations 5800, 5801, 5841, 5845, 5851, 5855, 5860), no steer axle sensor is needed.
- For scales where the steer axle weight is intentionally not displayed (configurations 5803, 5816, 5844, 5850), no steer axle sensor is needed.
- When installing kits with configurations 5807, 5808, 5828, 5843, 5846, 5853, 5857 or 5878, which include steer axle deflection sensors, refer to the Steer Axle Deflection Sensor Kit Installation Guide, for installation instructions.

IMPORTANT SENSOR INSTALLATION INSTRUCTIONS

Note: Calculated steer model numbers require the vehicle to have a 5th wheel

Kit Configuration Sensor Assignment

Number See Kit Part Number for Model Number	Sensor Installed on this Suspension HCV = Height Control Valve DS = Deflection Sensor	Sensor Type AP = Air Pressure Sensors DS = Deflection Sensor HY = Hydraulic Sensor LC = Load Call	ComLink Sensor Cable Input Jack
5800	Drive	AP	Sensor A
	Steer	Calculated	N/A
5801	Drive, Dual HCV's or other dual sensors	AP, AP	Sensor A & B
	Steer	Calculated	N/A
5803	Drive, Hide Steer	AP	Sensor A
5805	Drive	AP	Sensor A
	Steer	AP	Sensor B
5806	Drive, Dual HCV's or other dual sensors	AP, AP	Sensor A & B
	Steer	AP	Sensor C
5807	Drive	AP	Sensor A
	Steer	DS	Sensor B
5808	Drive, Dual HCV's or other dual sensors	AP, AP	Sensor A & B
	Steer	DS	Sensor C
5809	Drive, Hide Steer	LC or HY	Sensor A
5810	Drive, Dual DS's, Hide Steer	DS, DS	Sensor A & B
5814	Drive, Dual HCV's or other dual sensors	DS, DS	Sensor A & B
	Steer	DS	Sensor C
5815	Drive, Dual HCV's or other dual sensors	AP, AP	Sensor A & B
	Steer, Dual HCV's or other dual sensors	AP, AP	Sensor C & D
5816	Drive, Dual HCVs, Hide Steer	AP, AP	Sensor A & B
5817	Drive	DS	Sensor A
	Steer	DS	Sensor B
5821	Drive	AP	Sensor A
	<not used>	N/A	Sensor B
	Steer, Dual HVS's or other dual sensors	AP, AP	Sensor C & D
5825	Drive, Dual HCV's or other dual sensors	AP, AP	Sensor A & B
	Steer, Dual DS's	DS, DS	Sensor C & D

Number See Kit Part Number for Model Number	Sensor Installed on this Suspension HCV = Height Control Valve	Sensor Type AP = Air Pressure Sensors DS = Deflection Sensor LC = Load Call	ComLink Sensor Cable Input Jack
5828	Drive	AP	Sensor A
	<not used>	N/A	Sensor B
	Steer, Dual DS's	DS, DS	Sensor C & D
5832 Trailer Dedicated	Drive	DS	Sensor A
	Steer	Calculated	N/A
	Trailer	AP	Sensor B
5833 Truck	Drive	DS, DS	Sensor A & B
	Steer	DS	Sensor C
	Lift	AP	Sensor D
5834 Truck	Drive	DS	Sensor A
	Steer	DS	Sensor B
	Lift	AP	Sensor C
5835 Truck	Drive	AP	Sensor A
	Steer	DS	Sensor B
	Lift	AP	Sensor C
5836 Truck	Drive, Dual HCVs	AP, AP	Sensor A & B
	Steer	DS	Sensor C
	Lift	AP	Sensor D
5839 Truck	Drive	DS	Sensor A
	Steer	DS	Sensor B
	Pusher Lift	AP	Sensor C
	Tag Lift	AP	Sensor D
Trailer Dedicated 5840	Drive, Hide Steer	AP	Sensor A
	Trailer, Trailer - B - Train	AP, AP	Sensor B & C
Trailer Dedicated 5841	Drive	AP	Sensor A
	Steer	Calculated	N/A
	Trailer, Trailer - B - Train	AP, AP	Sensor B & C
Trailer Dedicated 5843	Drive	AP	Sensor A
	Steer	DS	Sensor B
	Trailer, Trailer - B - Train	AP, AP	Sensor C & D

Number See Kit Part Number for Model Number	Sensor Installed on this Suspension HCV = Height Control Valve	Sensor Type AP = Air Pressure Sensors DS = Deflection Sensor LC = Load Call	ComLink Sensor Cable Input Jack
Trailer Dedicated 5844	Drive, Dual HCVs	AP, AP	Sensor A & B
	Trailer, Trailer - B - Train	AP, AP	Sensor C & D
Trailer Dedicated 5845	Drive, Dual HCVs	AP, AP	Sensor A & B
	Steer	Calculated	N/A
	Trailer, Trailer - B - Train	AP, AP	Sensor C & D
Trailer Dedicated 5849	Drive	DS	Sensor A
	Steer	Calculated	N/A
Trailer Dedicated 5851	Drive	AP	Sensor A
	Steer	Calculated	N/A
	Trailer	AP	Sensor B
Trailer Dedicated 5852	Drive	AP	Sensor A
	Steer	AP	Sensor B
	Trailer	AP	Sensor C
Trailer Dedicated 5853	Drive	AP	Sensor A
	Steer	DS	Sensor B
	Trailer	AP	Sensor C
Trailer Dedicated 5855	Drive, Dual HCVs	AP, AP	Sensor A & B
	Steer	Calculated	N/A
	Trailer	AP	Sensor C
Trailer Dedicated 5857	Drive, Dual HCVs	AP, AP	Sensor A & B
	Steer	DS	Sensor C
	Trailer	AP	Sensor D
Trailer Dedicated 5860	Drive, Dual HCVs	AP, AP	Sensor A & B
	Steer	Calculated	N/A
	Trailer, Dual HCVs	AP, AP	Sensor C & D
Trailer Dedicated 5864	Drive	AP	Sensor A
	Steer	DS	Sensor B
	Pusher Lift	AP	Sensor C
	Tag Lift	AP	Sensor D

Limited Warranty

Air-Weigh warrants (the "Limited Warranty") that the Products will be free from defects in material and workmanship under normal use and service with proper maintenance for the following time periods:

- (a) for new Scale kits, the Limited Warranty period will be 3 years;
- (b) for new parts and accessories sold separately, the Limited Warranty period will be 1 year; and
- (c) for repaired or refurbished items, including repaired or refurbished Scale kits and repaired or refurbished parts and accessories sold separately, the Limited Warranty period will be 90 days.

If any Product is determined to not conform to this Limited Warranty during its applicable Limited Warranty period, Air-Weigh will, at its exclusive option, either repair or replace the Product.

Limitations of Limited Warranty. Air-Weigh will have no obligation under the Limited Warranty with respect to any product if (a) Buyer fails to notify Air-Weigh in writing during the warranty period of a non-conformity, or (b) Buyer or any other person, entity, or governmental authority uses, misuses, or neglects the product in a manner inconsistent with the product's specifications or directions for use or maintenance, modifies the product or improperly installs, handles, or maintains the product.

No Repair or Modification of the products. Except as explicitly authorized or in a separate written agreement with Air-Weigh, Buyer will not service, repair, modify, alter, replace, reverse engineer, or otherwise change any of the products.

Disclaimer of All Other Warranties. EXCEPT FOR THE LIMITED WARRANTIES SET OUT ABOVE, NEITHER AIR-WEIGH NOR ANY PERSON OR ENTITY ON AIR-WEIGH'S BEHALF HAS MADE OR MAKES FOR BUYER'S BENEFIT ANY EXPRESS OR IMPLIED REPRESENTATION OR WARRANTY WHATSOEVER, INCLUDING ANY WARRANTIES OF: (i) MERCHANTABILITY; (ii) FITNESS FOR A PARTICULAR PURPOSE; (iii) TITLE; OR (iv) NON-INFRINGEMENT; WHETHER ARISING BY LAW, COURSE OF DEALING, COURSE OF PERFORMANCE, USAGE OF TRADE OR OTHERWISE, ALL OF WHICH ARE EXPRESSLY DISCLAIMED. BUYER ACKNOWLEDGES THAT IT HAS NOT RELIED ON ANY OTHER REPRESENTATION OR WARRANTY MADE BY AIR-WEIGH, OR ANY OTHER PERSON OR ENTITY ON AIR-WEIGH'S BEHALF.

Limitation of Liability.

IN NO EVENT WILL AIR-WEIGH BE LIABLE FOR CONSEQUENTIAL, INDIRECT, INCIDENTAL, SPECIAL, EXEMPLARY, PUNITIVE, OR ENHANCED DAMAGES, LOST PROFITS OR REVENUES, OR DIMINUTION IN VALUE, ARISING OUT OF OR RELATING TO ANY BREACH OF THESE TERMS, REGARDLESS OF WHETHER OR NOT THE DAMAGES WERE FORESEEABLE, WHETHER OR NOT AIR-WEIGH WAS ADVISED OF THE POSSIBILITY OF THE DAMAGES, OR THE LEGAL OR EQUITABLE THEORY (CONTRACT, TORT, OR OTHERWISE) ON WHICH THE CLAIM IS BASED.

IN NO CASE WILL AIR-WEIGH'S AGGREGATE LIABILITY ARISING OUT OF OR RELATED TO THESE TERMS, WHETHER ARISING OUT OF OR RELATED TO BREACH OF CONTRACT, TORT (INCLUDING NEGLIGENCE), OR OTHERWISE, EXCEED THE TOTAL OF THE AMOUNTS PAID TO AIR-WEIGH FOR THE PRODUCTS.

THE FOREGOING LIMITATIONS APPLY EVEN IF BUYER'S REMEDIES UNDER THESE TERMS FAIL OF THEIR ESSENTIAL PURPOSE.

Procedure For Warranty Claims

ALL customers should first contact Air-Weigh Customer Support Department at (888) 459-3247 for questions regarding the use, operation, repair or return of any Air-Weigh product.

In the event Air-Weigh requests to examine the product prior to disposition OR for repair or replacement, Air-Weigh requires a Return Material Authorization (RMA) number be issued before the item is returned. Customer Support will issue the RMA number. Please reference this RMA number in all correspondence.

Claimed items shall be shipped freight pre-paid to:

Air-Weigh
Customer Support Department
1720 Willow Creek Circle, Suite 510
Eugene, Oregon 97402, USA

The Air-Weigh RMA number **must** appear on the outside of the return packaging. Air-Weigh shall examine returned material within 30 days after receipt, or sooner if mutually agreed upon. If Air-Weigh determines that the part or assembly was defective in material or workmanship and within the warranty period, Air-Weigh will repair or replace the part or assembly and return freight pre-paid. In the event Air-Weigh determines that the part or assembly cannot be repaired or replaced and is within the warranty period, a credit not to exceed the purchase price will be issued to the Air-Weigh customer.

For our customers using purchase orders Air-Weigh will process a credit memo and notify the customer by email or fax. The customer will process a corresponding debit memo and notify Air-Weigh accordingly.

If the part or assembly received by Air-Weigh does not meet the requirements of the warranty program set forth above, at the Air-Weigh customer's request the part or assembly will either be discarded, returned freight collect, or repaired or replaced at the Air-Weigh customer's expense and returned freight collect.

Air Weigh

1730 Willow Creek Circle • Eugene, OR 97402-9152 USA
P.O. Box 24308 • Eugene, OR 97402-0437 USA

Telephone (541) 343-7884 • Order Desk (888) 459-3444
Customer Support (888) 459-3247 • Fax (541) 431-3121

www.Air-Weigh.com | awsales@air-weigh.com